

Mounting and Installing the TV

IMPORTANT: Remove the stand that is attached to your Flat Screen TV. Carefully measure all dimensions on your TV before proceeding. Consult the handy Dimensions Chart in the back of this Manual for maximum TV size guidelines for each of our TV Lift cabinets.

Step 1: Lean your Flat Screen TV on its edge against a sofa or other soft surface.

Step 2: Find the 4 mounting holes on the back of your TV and then choose the 4 screws from the Hardware Pack that work best for your TV and prepare to affix the TV Mounting Brackets (2) provided onto the back of the TV.

Step 3: Fix the TV mounting brackets to the TV.

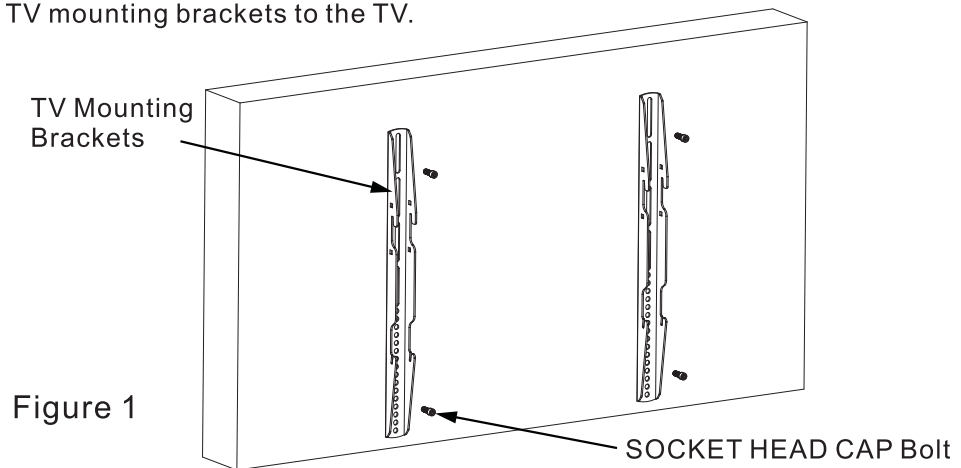

Step 4: Prepare to Mount the TV. Plug in the Lift and raise it to the full height so it is fully extended. For optimum performance of your lift and to insure that the Roller Balls are gently lifting the lid (not the top of the TV), when mounting your TV on the Mounting Plate the top of your TV should be no higher than level with or slightly below (1/4" or more) the Roller Balls on top of the lift.

Step 5: Hang the TV with brackets to the mounting plate: First, hang the top of two brackets to the mounting plate. After the top of brackets hook to the horizontal rail, slowly release the TV to make sure it is firmly hooked on.

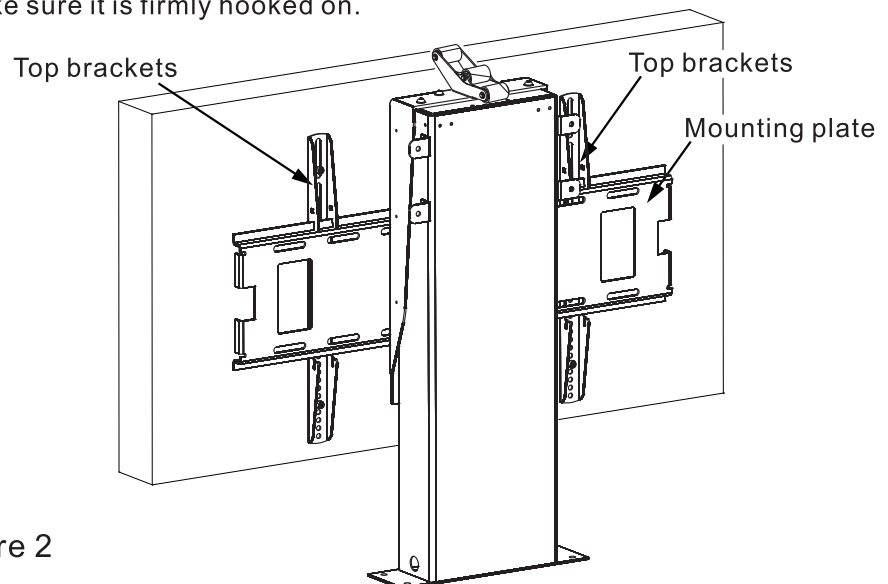

Step 6: Lock the TV mounting brackets with the L brackets. Slide to the slot and turn the butterfly bolt until it stops.

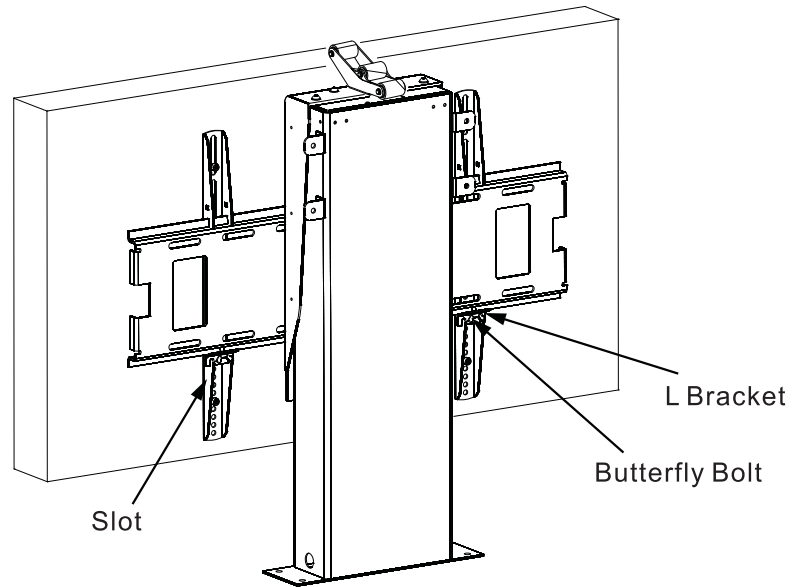

Figure 3

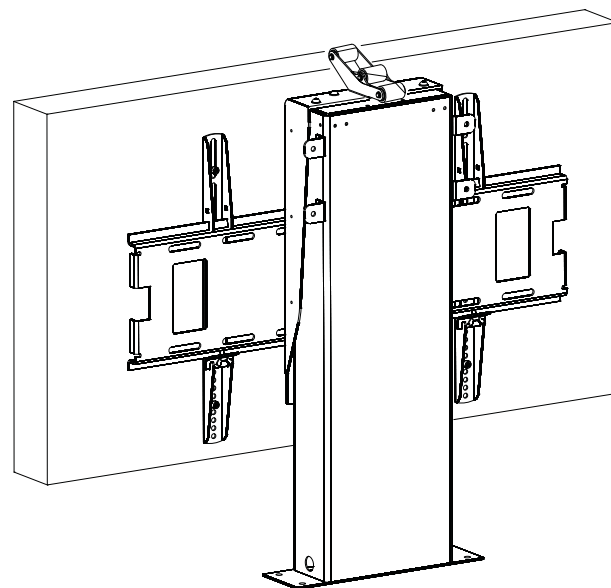

Figure 4